

## Dreibacken-Keilstangenfutter mit Stangendurchlass Three jaw wedge bar chuck with through hole

**KH**



### Konstruktionsmerkmale

BERG-Kraftspannfutter der Bauart KH sind für Hochleistungsdrehmaschinen ausgelegt. Sie zeichnen sich durch hohe Spannkraft und Spanngenauigkeit sowie durch hohe Maximaldrehzahl und geringe Bauhöhe aus.

Ein Futterkolben treibt Keilstangen an, von denen jeweils zwei einer Grundbacke zugeordnet sind und diese in Spannrichtung bewegen. Die konsequente Reduktion aller Massen, die der Fliehkraft ausgesetzt sind, sowie der hervorragende Wirkungsgrad des Spanngetriebes machen die sonst bei Hochleistungsfuttern notwendigen fliehkraftkompensierenden Getriebeteile überflüssig. Gleichzeitig ist damit die Spannkrafthysterese, d. h. die für verformungsempfindliche Werkstücke schädliche Spannkraftüberhöhung, ausgeschlossen. KH-Kraftspannfutter sind daher sowohl für die schwere Schrappzerspanung mit hohen Spannkraften als auch für die genaue Feinbearbeitung bei hohen Drehzahlen geeignet.

KH-Kraftspannfutter stehen in der Ausführung Z für zylindrische Flachflanschspindeln und in der Ausführung A für Spindelköpfe nach DIN 55026 zur Verfügung.

### Design features

BERG power operated chucks type KH are designed for high speed, high capacity lathes. They stand out for their high clamping force and precision, as well as high maximum rotational speed and low construction height.

A chuck piston drives the wedge bars, of which two are assigned to one base jaw, moving them in the clamping direction. The consistent reduction of all mass exposed to the centrifugal force, as well as the high efficiency of the clamping drive make centrifugal force compensation mechanism, otherwise required by high speed chucks, unnecessary. At the same time, the development of clamping force hysteresis is prevented, i. e. an excess in clamping force which negatively affects workpieces sensitive to deformation. This makes KH power operated chucks suitable for both chip removal by roughing under high clamping forces and precise finishing at high rotational speeds.

KH power operated chucks are available as type Z for cylindrical flat flange spindles and as type A for spindle heads as per DIN 55026.

# Dreibacken-Keilstangenfutter mit Stangendurchlass

## Three jaw wedge bar chuck with through hole



### Kurzzeichen

$F_1$	kN	Betätigungskraft
$F_2$	kN	Spannkraft pro Backe bei $n = 0$
$\Sigma F_2$	kN	Summenspannkraft des Futter bei $n = 0$
$x$	mm	Spannabstand
$K_1, K_2$	mm	Futterkonstante
$n_{max.}$	$min^{-1}$	Höchstzahl
$m$	kg	Masse
$I$	$kgm^2$	Trägheitsmoment

### Abbreviations

$F_1$	kN	Operating force
$F_2$	kN	Clamping force per jaw at $n = 0$
$\Sigma F_2$	kN	Total clamping force of the chuck at $n = 0$
$x$	mm	Clamping distance
$K_1, K_2$	mm	Chuck constant
$n_{max.}$	rpm	Maximum rotational speed
$m$	kg	Mass
$I$	$kgm^2$	Moment of inertia

### Bestellbeispiel

Kraftspannfutter KH 110/30-Z4  
 Harte Aufsatzbacken HB 211  
 Weiche Aufsatzbacken WB 211

### Ordering example

Power operated chuck KH 110/30-Z4  
 Hard top jaws HB 211  
 Soft top jaws WB 211

### Lieferumfang

Kraftspannfutter KH nach Datenblatt einschließlich Futterbefestigungsschrauben, T-Nutenschrauben und Muttern, Handhebel Fett- presse PFD 6, Fettpatrone HFP 805

### Delivery scope

Power operated chuck KH according to data sheet including chuck fixing screws, T-tenon screws and nuts, hand lever grease gun PFD 6, grease cartridge HFP 805

### Zubehör

Harte Aufsatzbacken	HB
Harte Greiferbacken (Außenspannung)	HGKHA
Harte Greiferbacken (Innenspannung)	HGKHI
Harte Stangenspannbacken	HBS
Weiche Aufsatzbacken	WB
Weiche Aufsatzbacken, ohne Bohrung	WBO
Drehbarer Kolbenanschluss	Auf Anfrage
Verstellbarer Innenanschlag	HLKL auf Anfrage
Verstellbarer Innenanschlag	TLKL auf Anfrage

### Accessories

Hard top jaws HB	
Hard gripping jaws (external clamping)	HGKHA
Hard gripping jaws (internal clamping)	HGKHI
Hard top jaws for bar clamping	HBS
Soft top jaws	WB
Soft top jaws, without bore	WBO
Rotary piston connection	On request
Adjustable internal stop	HLKL on request
Adjustable internal stop	TLKL on request

### Anmerkung

Kolbenanschlag vorn: im Betätigungszylinder  
 Kolbenanschlag hinten: am Futterflansch oder an der Arbeitsspindel

### Comment

Piston stop at the front: in the actuating cylinder  
 Piston stop at the back: at the chuck flange or the spindle

Aufsatzbacken sind grundsätzlich so leicht wie möglich und mit kleinem Spannabstand  $x$  auszuführen.

Top jaws should always be made as light as possible with a short clamping distance  $x$ .

### Summenspannkraft

$$\Sigma F_2 = F_{1. max.} \frac{K_1}{K_2 + x}$$

### Total clamping force

$$\Sigma F_2 = F_{1. max.} \frac{K_1}{K_2 + x}$$



# Dreibacken-Keilstangenfutter mit Stangendurchlass Three jaw wedge bar chuck with through hole

## KH-A, KH-Z

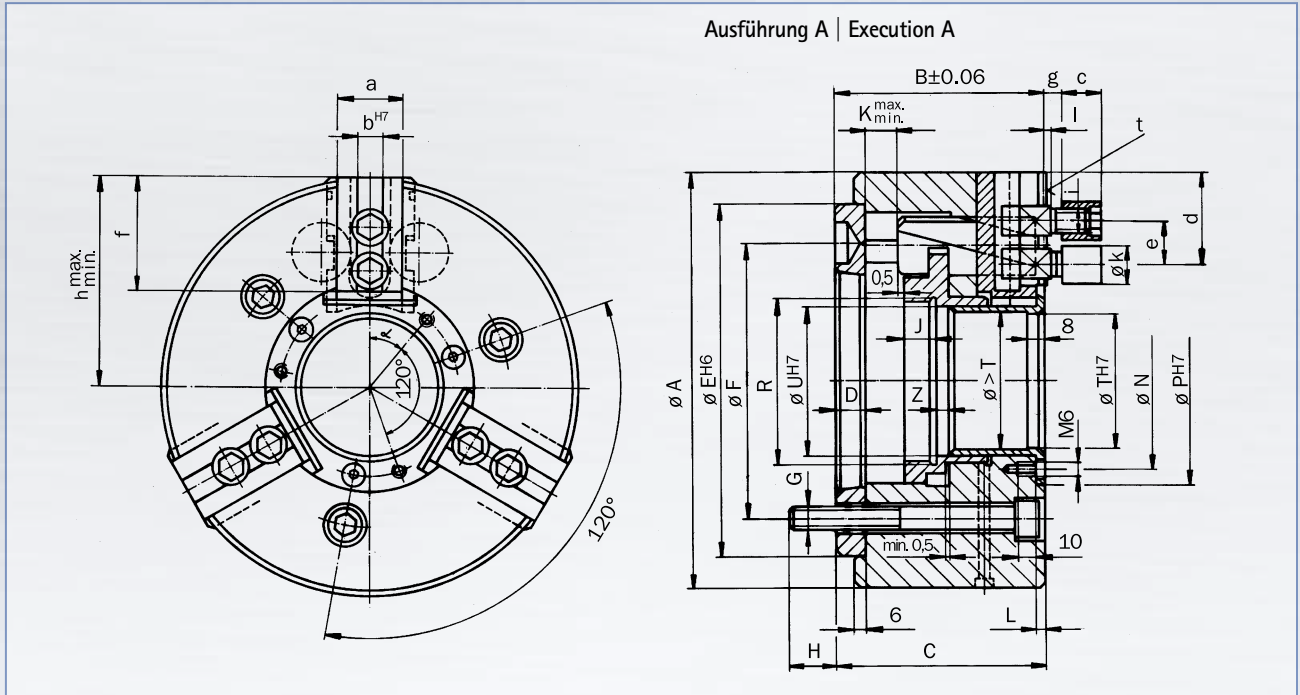

### Maße | Dimensions

TYP   TYPE	A	B	C	D	E	F	G	H	J	K <sub>max.</sub>	K <sub>min.</sub>	L	N	α	P	R	T	U	Z	U <sub>min.</sub>	a	b	c	d <sub>max.</sub>	e <sub>min.</sub>	f	g	h <sub>max.</sub>	h <sub>min.</sub>	i	k	l	t
KH 110/30-A4	110	81,5	80,5	11,5	100	82,6	3xM 10	13,5	14	13,5	0	3,5	44	48,5°	57	M38x1,5	30	34	6	24	8	13	27,0	14,3	31,8	7	57,0	54,0	M9x1	13,0	2,5	1/16" x 90°	
KH 140/36-A5	140	92,5	91,5	13,5	125	104,8	3xM 10	21,5	16	13,5	0	3,5	51	50,0°	62	M45x1,5	36	40	6	28	10	16	35,5	17,0	44,5	7	72,5	69,5	M10	16,0	2,5	1/16" x 90°	
KH 160/45-A5	160	92,5	91,5	13,5	140	104,8	3xM 10	21,5	16	13,5	0	3,5	60	50,0°	71	M55x1,5	45	50	6	28	10	16	40,5	17,0	49,5	7	82,5	79,5	M10	16,0	2,5	1/16" x 90°	
KH 200/68-A5	200	100,0	99,0	13,0	170	104,8	3xM 10	22,0	16	17,5	0	3,5	85	40,0°	100	M80x1,5	68	72	6	32	12	19	44,0	21,0	54,0	8	100,0	96,0	M12	17,8	2,5	1/16" x 90°	
KH 200/68-A6	200	101,0	100,0	14,0	170	133,4	3xM 12	24,0	16	17,5	0	3,5	85	40,0°	100	M80x1,5	68	72	6	32	12	19	44,0	21,0	54,0	8	100,0	96,0	M12	17,8	2,5	1/16" x 90°	
KH 250/91-A6	250	116,0	115,0	14,0	220	133,4	3xM 12	24,0	20	17,5	0	5,0	110	40,0°	125	M102x1,5	91	98	10	40	16	25	50,5	29,0	65,0	10	125,0	121,0	M16	24,5	3,0	1/16" x 90°	
KH 250/91-A8	250	118,5	117,5	16,5	220	171,4	3xM 16	27,5	20	17,5	0	5,0	110	40,0°	125	M102x1,5	91	98	10	40	16	25	50,5	29,0	65,0	10	125,0	121,0	M16	24,5	3,0	1/16" x 90°	
KH 315/117-A8	315	118,0	117,0	16,0	300	171,4	3xM 16	27,0	20	17,5	0	5,0	140	40,0°	155	M130x1,5	117	125	10	40	16	25	69,5	29,0	84,0	10	157,5	153,5	M16	24,5	3,0	1/16" x 90°	
KH 315/117-A11	315	120,5	119,5	18,5	300	235,0	3xM 20	31,5	20	17,5	0	5,0	140	40,0°	155	M130x1,5	117	125	10	40	16	25	69,5	29,0	84,0	10	157,5	153,5	M16	24,5	3,0	1/16" x 90°	
KH 400/165-A11	400	143,0	142,0	18,0	380	235,0	3xM 20	32,0	25	22,0	0	6,0	190	40,0°	205	M180x3,0	165	175	12	50	20	32	80,0	38,0	97,0	12	200,0	195,0	M20	32,0	4,0	3/32" x 90°	
KH 400/165-A15	400	144,5	143,5	19,5	380	330,2	3xM 24	36,5	25	22,0	0	6,0	190	40,0°	205	M180x3,0	165	175	12	50	20	32	80,0	38,0	97,0	12	200,0	195,0	M20	32,0	4,0	3/32" x 90°	

### Technische Daten | Technical data

TYP   TYPE	F <sub>1 max.</sub> kN	n min <sup>-1</sup>	m kg	I kgm <sup>2</sup>	K <sub>1</sub> mm	K <sub>2</sub> mm
KH 110/30-A4	20	8000	4,4	0,008	360	160
KH 140/36-A5	25	6300	7,5	0,025	420	180
KH 160/45-A5	25	6300	11,0	0,040	430	150
KH 200/68-A5	40	6300	17,5	0,071	550	210
KH 200/68-A6	40	6300	17,5	0,071	550	210
KH 250/91-A6	60	4500	30,0	0,240	750	290
KH 250/91-A8	60	4500	30,0	0,240	750	290
KH 315/117-A8	60	4000	51,0	0,650	950	360
KH 315/117-A11	60	4000	51,0	0,650	950	360
KH 400/165-A11	100	3150	110,0	2,200	980	390
KH 400/165-A15	100	3150	110,0	2,200	980	390

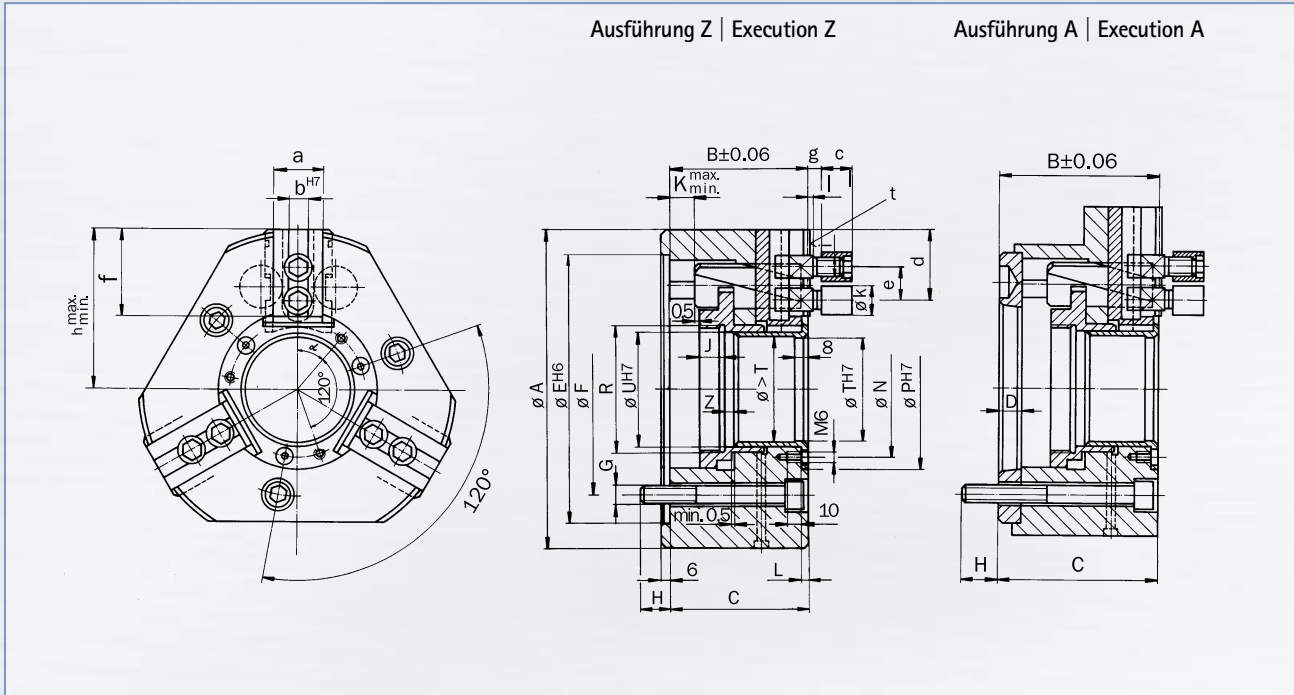

## Maße | Dimensions

TYP   TYPE	A	B	C	D	E	F	G	H	J	K <sub>max</sub>	K <sub>min</sub>	L	N	α	P	R	T	U	Z	U <sub>min</sub>	a	b	c	d	e <sub>max</sub>	e <sub>min</sub>	f	g	h <sub>max</sub>	h <sub>min</sub>	i	k	l	t	
KH 500/165-Z15	500	125,0	124,0	-	380	330,2	3 x M 24	36,0	25	22	0	6	190	40°	205	M 180 x 3	165	175	12	50	20	32	130	38	147	12	250	245	M 20	32	4	3/32" x 90°			
KH 500/165-A15	500	144,5	143,5	19,5	380	330,2	3 x M 24	36,5	25	22	0	6	190	40°	205	M 180 x 3	165	175	12	50	20	32	130	38	147	12	250	245	M 20	32	4	3/32" x 90°			
KH 630/165-Z15	630	125,0	124,0	-	380	330,2	3 x M 24	36,0	25	22	0	6	190	40°	205	M 180 x 3	165	175	12	50	20	32	195	38	212	12	315	310	M 20	32	4	3/32" x 90°			
KH 630/165-A15	630	144,5	143,5	19,5	380	330,2	3 x M 24	36,5	25	22	0	6	190	40°	205	M 180 x 3	165	175	12	50	20	32	195	38	212	12	315	310	M 20	32	4	3/32" x 90°			

## Technische Daten | Technical data

TYP   TYPE	F <sub>1 max.</sub> kN	n min <sup>-1</sup>	m kg	I kgm <sup>2</sup>	K <sub>1</sub> mm	K <sub>2</sub> mm
KH 500/165-Z15	100	2240	120	3,0	1200	450
KH 500/165-A15	100	2240	130	3,2	1200	450
KH 630/165-Z15	100	1800	165	4,2	1700	650
KH 630/165-A15	100	1800	150	4,4	1700	650